

**Output Type:**  
PWM

**Voltage:**  
Up to 40 VDC

**Amperage:**  
Up to 10 A Peak

**Mounting:**  
3U Rack Mount

**Modes:**  
Velocity or Torque

**Command:**  
PWM Drive or  $\pm 10V$

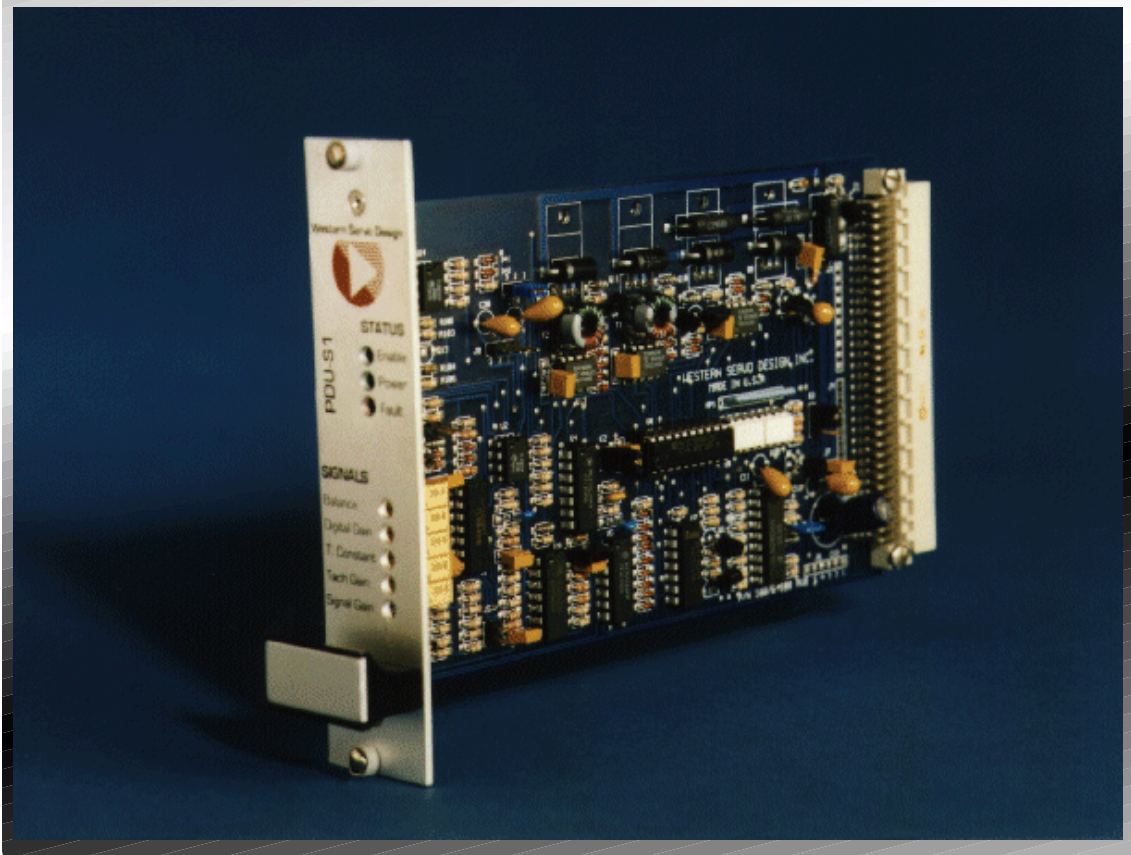

# PDU-S1

Medium-Power Brush-Type PWM Servo Amplifier

The PDU-S1 is a medium power, brushed PWM servo amplifier in a 3U Eurocard form factor. Control can come from an analog ( $\pm 10V$ ) command, or digital Magnitude and Direction signals. This multi-purpose amplifier contains both Velocity and Torque feedback loops. Inputs are provided to allow tachometer feedback in the Velocity Mode. The Torque Mode can be used for torque control applications, or in conjunction with a digital servo controller capable of computing Position and Velocity loop values. The high switching frequency of the PAU-S1 allows the amplifier to drive very low inductance loads.

The PDU-S1 has Under Bias Voltage shutdown as well as Over Current and Over Voltage protection. Fault conditions are reported digitally to the controller connections, and indicated visually by front panel LEDs.

An optional backplane is available to allow quick and easy access to motor, power, control and other I/O signals. This greatly simplifies implementing the PDU-S1 in a motion control system.

- ◉ Eurocard 3U Form Factor
- ◉ Digital Control of PWM using Magnitude and Direction Signals
- ◉ Jumper Selectable Velocity or Torque Modes
- ◉ Visual and Digital Fault Indicators
- ◉ Over Voltage, Over Current and Under Bias Protection
- ◉ PWM Frequency: 80 kHz
- ◉ Continuous Current: 5 Amperes
- ◉ High Bandwidth
- ◉ Bus Voltage: 20 - 40 VDC
- ◉ Advanced Design, High Quality and High Reliability at a Lower Cost

## SPECIFICATIONS

Standard Models:	4/10	4/10
Bus Voltage	20 to 40 VDC	20 to 60 VDC
Peak Output Current*	10 A for 0.5 sec	10 A for 0.5 sec
Continuous Output Current*	5 A	5 A
Command Input Voltage	0 to ±10V	0 to ±10V
Command Input Impedance	20 kOhm	20 kOhm
Switching Frequency	80 kHz	80 kHz
Minimum Load Inductance	0.1 mH	0.1 mH
Torque Gain	1 A/V	1 A/V
Bandwidth	20 kHz	20 kHz
Weight	1.25 Lb (566.99 g)	
Recommended Chassis	CHU-S3 or CHU-S6 Eurocard	
Available Accessories	ACC-V1A Backplane, ACC-V2B Inductor Board, PCU-S1 Rack Mount Power Supply, ACC-V3A PMAC Interface Board	

\*All ratings with forced air cooling to maintain 40°C heat sink temperature. Failure to keep constant air flow to the heat sink will reduce the output current capacity and may result in damage to the unit.

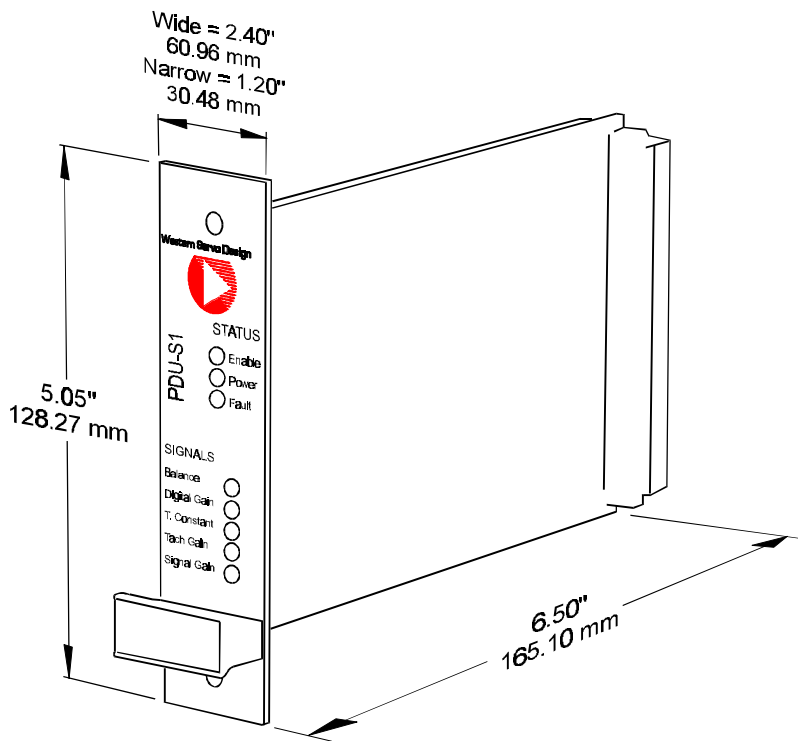

## PINOUTS

### J1: SIGNALS & BIAS POWER

#### ROW A

Pin	Function
1 - 3	Motor Phase A (+)
4 - 6	Motor Phase B (-)
7	No Connection
8	+ Bias In (+12 to +15 VDC)
9	Ground
10	- Bias In (-12 to -15 VDC)
11	Digital PWM Command In
12	Digital Direction Command In
13	PWM Opto Power In
14	Bias Under Voltage Fault Out
15	Over Temp Fault Out
16	Over Current Fault Out
17	Over Bus Voltage Fault Out
18	Global Amp Fault Out
19	Amp PWM Clock Out
20	+ Limit In
21	Ground
22	- Limit In
23	Ground
24 - 26	No Connection
27 - 29	Bus Ground
30 - 32	Bus +V

#### ROW B

Pin	Function
1 - 3	Motor Phase A (+)
4 - 6	Motor Phase B (-)
7 - 26	No Connection
27 - 29	Bus Ground
30 - 32	Bus +V

#### ROW C

Pin	Function
1 - 3	Motor Phase A (+)
4 - 6	Motor Phase B (-)
7	No Connection
8	+ Bias In (+12 to +15 VDC)
9	Ground
10	- Bias In (-12 to -15 VDC)
11	Amp Enable In
12	Current Monitor Out
13	+ Tachometer In
14	- Tachometer In
15	Ground
16	Command Return (analog)
17	Command In (analog)
18 - 23	No Connection
24	Velocity or Current Mode Select
25 - 26	No Connection
27 - 29	Bus Ground
30 - 32	Bus +V

Consult the User's Manual for jumper settings and Backplane connections.

### Ordering Information:

Product	Order Number
PDU-S1-4/10 Amp 40 VDC/10A Peak	WS-010-0001
PDU-S1-6/10 Amp 60 VDC/10A Peak	WS-010-0002
ACC-V1A Backplane	WS-011-0003
ACC-V2B Inductor Board	WS-011-0006

### Represented By:

