

**Output Type:**  
PWM

**Voltage:**  
Up to 170 VDC

**Amperage:**  
Up to 30 A Peak

**Mounting:**  
3U Eurocard

**Modes:**  
Torque

**Commutation:**  
Ext Sine or Digital Hall

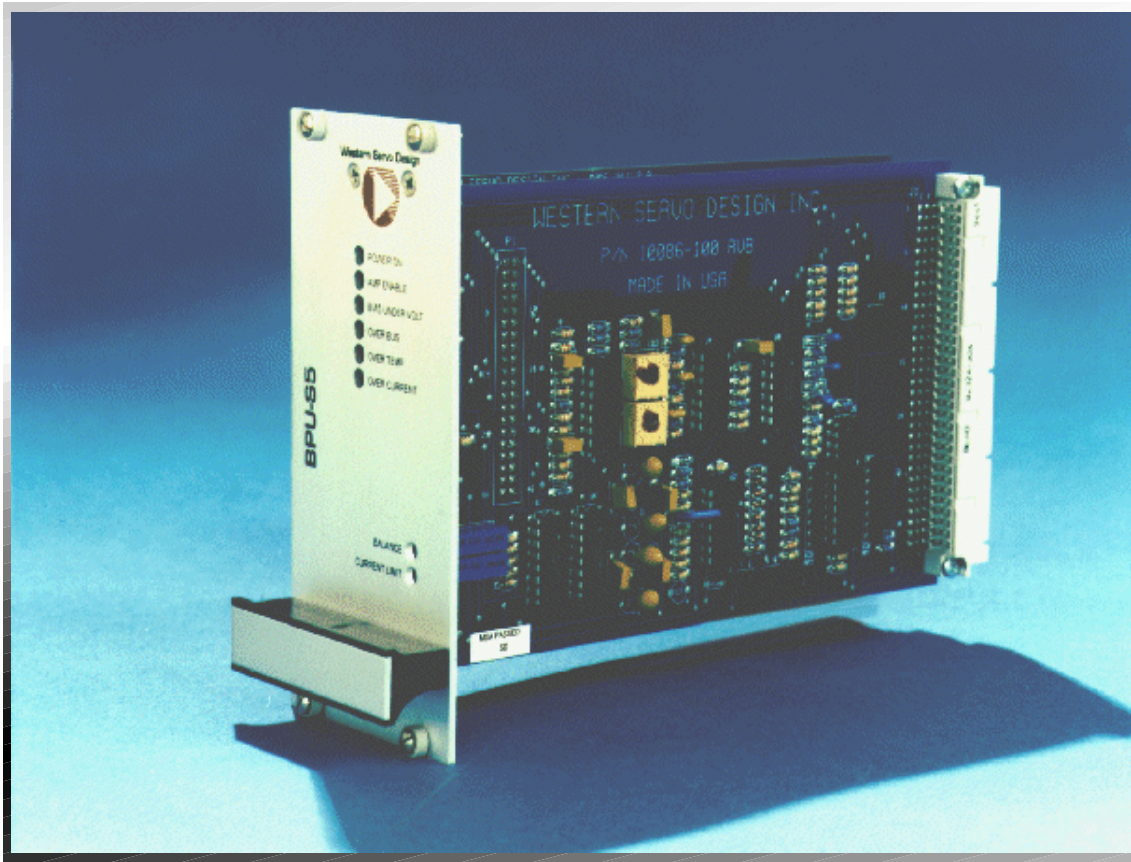

# BPU-S5

High-Power Brushless PWM Servo Amplifier

The BPU-S5 is a high power brushless PWM servo amplifier in a Eurocard 3U form factor. It is ideally suited to torque control applications or for velocity control using a digital position controller. This amplifier can be configured for external sinusoidal commutation or for self commutation using digital Hall effect sensors. This unit is similar to the BPU-S2 but in a smaller form factor due to a lower maximum voltage rating. Look to the BPU-S4 if analog Hall sensors are required.

The BPU-S5 is a double card unit, consisting of separate Power and Personality Modules. The Personality Module adds digital status reporting capability, inputs for Hall effect sensors, and allows future amplifier reconfiguration with modules under development at Western Servo Design. Hall effect commutation or external sinusoidal commutation may be selected "on the fly" via digital switching. When using external sinusoidal commutation, the amplifier receives two 120° out of phase sinusoidal command inputs. The optimal third phase is derived by the amplifier. This eliminates "cogging" and greatly enhances low speed operation. An optional backplane is available to allow quick and easy access to motor, power, control and other I/O signals.

- ◉ Eurocard 3U Form Factor
- ◉ Accepts Digital Hall Effect Sensors
- ◉ Two Commutation Modes: Hall Effect and External Sinusoidal Input
- ◉ High Speed Commutation Mode selection using Digital Switching
- ◉ 4 Digital Status Outputs plus Global Fault
- ◉ Travel Limits and Amp Enable Inputs
- ◉ Protected from Over Current, Over Voltage, and Under Bias
- ◉ Current Monitor Output
- ◉ PWM Frequency: 20 kHz or 80 kHz
- ◉ Bus Voltage: 30 - 170 VDC
- ◉ Continuous Current: 5, 8 or 12 Amperes
- ◉ Full Isolation between Input and Output Circuits
- ◉ Designed for Three-Phase Wye or Delta Wound Motors
- ◉ Advanced Design, Superior Quality and High Reliability
- ◉ One Year Parts and Labor Warranty

## SPECIFICATIONS

Standard Models:	10/10	17/15	17/30
Maximum Bus Voltage	100 VDC	170 VDC	170 VDC
Peak Output Current*	10 A for 0.5 sec	15 A for 0.5 sec	30 A for 0.5 sec
Continuous Output Current*	5 A	8 A	12 A
Command Input Voltage: Hall Commutation Sinusoidal Commutation	0 to ±10 V 0 to ±5 V	0 to ±10 V 0 to ±5 V	0 to ±10 V 0 to ±5 V
Command Input Impedance	10 kOhm	10 kOhm	10 kOhm
Minimum Load Inductance	0.2 mH	2 mH	2 mH
Switching Frequency	80 kHz	20 kHz	20 kHz
Torque Gain: Hall Mode Sinusoidal Mode	1.0 A/V 2.0 A/V	1.5 A/V 3.0 A/V	3.0 A/V 6.0 A/V
Bandwidth	13 kHz	4 kHz	2 kHz
Weight	.96 Lb (435 grams)		
Recommended Chassis	CHU-S3 or CHU-S6 Eurocard		
Available Accessories	ACC-V1F Backplane, ACC-V3A PMAC Interface Board, PSU-S1 Power Supply		

\*All ratings with forced air cooling to maintain 40°C heat sink temperature. Failure to keep constant air flow to the heat sink will reduce the output current capacity and may result in damage to the unit.

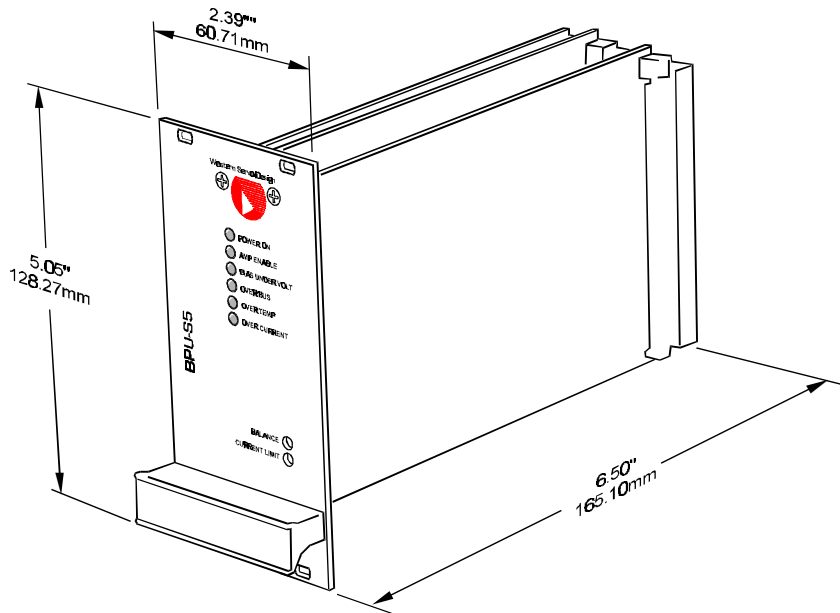

### Ordering Information:

Product	Order Number
BPU-S5-10/10 Amp 100 VDC/10A Peak	WS-007-0013
BPU-S5-17/15 Amp 170 VDC/15A Peak	WS-007-0014
BPU-S5-17/30 Amp 170 VDC/30A Peak	WS-007-0015
ACC-V1F Backplane	WS-914-0005

### Represented By:

## PINOUTS

### PERSONALITY MODULE J1

#### ROW A

Pin	Function (Hall Mode    Sine Mode)
2	+ Bias In (+12 to +15VDC)
4	Ground
6	Current Monitor Out
8	No Connection
10	Ground
12	Hall C    No Connection
14	Hall A    No Connection
16	Over Bus Fault Out
18	Over Current Fault Out
20	Amp Global Fault Out
22	Hall Shield    No Connection
24	+ Limit In    No Connection
26	Amp Enable In (low true)
28	No Connection
30	Command Return
32	Command In (-)    Phase 1 In

#### ROW C

Pin	Function (Hall Mode    Sine Mode)
2	- Bias In (-12 to -15VDC)
4	Ground
6	No Connection
8	No Connection
10	No Connection
12	Hall B    No connection
14	+12VDC Out for Hall power
16	Over Temp Fault Out
18	Bias Under Fault Out
20	No Connection
22	Ground
24	- Limit In    No Connection
26	Ground
28	No Connection
30	Sine/Hall Select In
32	Command In (+)    Phase 2 In

### POWER MODULE J1

#### ROWS A, B & C

Pin	Function
1 - 5	Bus +V
7 - 11	Bus Ground
13 - 17	Motor Phase C
19 - 23	Motor Phase B
25 - 29	Motor Phase A

See User's Manual for jumper settings and Backplane Connections.